



Huawei AP7110DN-AGN&7110SN-GN Access Points

V200R003C00

Product Description

Issue 01

Date 2013-04-30

Copyright © Huawei Technologies Co., Ltd. 2013. All rights reserved.

No part of this document may be reproduced or transmitted in any form or by any means without prior written consent of Huawei Technologies Co., Ltd.

Trademarks and Permissions



HUAWEI and other Huawei trademarks are trademarks of Huawei Technologies Co., Ltd.

All other trademarks and trade names mentioned in this document are the property of their respective holders.

Notice

The purchased products, services and features are stipulated by the contract made between Huawei and the customer. All or part of the products, services and features described in this document may not be within the purchase scope or the usage scope. Unless otherwise specified in the contract, all statements, information, and recommendations in this document are provided "AS IS" without warranties, guarantees or representations of any kind, either express or implied.

The information in this document is subject to change without notice. Every effort has been made in the preparation of this document to ensure accuracy of the contents, but all statements, information, and recommendations in this document do not constitute a warranty of any kind, express or implied.

Huawei Technologies Co., Ltd.

Address: Huawei Industrial Base
Bantian, Longgang
Shenzhen 518129
People's Republic of China

Website: <http://enterprise.huawei.com>

About This Document

Intended Audience

This document describes the positioning, characteristics, hardware structure, product features, and technical specifications of the AP.





This document helps you understand the characteristics and features of the AP.

This document is intended for:

- Network planning engineers
- Hardware installation engineers
- Commissioning engineer
- Data configuration engineers
- On-site maintenance engineers
- Network monitoring engineers
- System maintenance engineers

Symbol Conventions

The symbols that may be found in this document are defined as follows.

Symbol	Description
 DANGER	Indicates a hazard with a high level or medium level of risk which, if not avoided, could result in death or serious injury.
 WARNING	Indicates a hazard with a low level of risk which, if not avoided, could result in minor or moderate injury.
 CAUTION	Indicates a potentially hazardous situation that, if not avoided, could result in equipment damage, data loss, performance deterioration, or unanticipated results.
 TIP	Provides a tip that may help you solve a problem or save time.
 NOTE	Provides additional information to emphasize or supplement important points in the main text.

Change History

Changes between document issues are cumulative. The latest document issue contains all the changes made in previous issues.

Changes in Issue 01 (2013-04-30)

This is the initial commercial release.

Contents

About This Document.....	ii
1 Product Positioning and Characteristics.....	1
1.1 Product Positioning.....	2
1.2 Product Characteristics.....	5
2 Hardware Structure.....	8
2.1 AP7110DN-AGN.....	9
2.2 AP7110SN-GN.....	12
3 Product Features.....	15
3.1 WLAN Features.....	16
3.2 Network Features.....	16
3.3 QoS Features.....	17
3.4 Security Features.....	17
3.5 Maintenance Features.....	17
3.6 BYOD.....	18
3.7 Locating Service.....	18
3.8 Spectrum Analysis.....	18
4 Technical Specifications.....	19
4.1 Basic Specifications.....	20
4.2 Radio Specifications.....	20
4.3 Standards Compliance.....	28

1 Product Positioning and Characteristics

About This Chapter

[1.1 Product Positioning](#)

[1.2 Product Characteristics](#)

1.1 Product Positioning

Table 1-1 Product positioning

Product Model	Frequency Band	IEEE Standard Compliance	Positioning	Usage Scenario
AP7110DN-AGN	Dual band: <ul style="list-style-type: none"> ● 2.4 GHz ● 5 GHz The AP7110DN-AGN can provide services simultaneously on the 2.4 GHz and 5 GHz frequency bands to support more access users.	IEEE 802.11a/b/g/n	The AP7110DN-AGN is the latest generation technology-leading AP. It supports 3 x 3 MIMO and provides comprehensive service support capabilities. The AP7110DN-AGN is deployed indoors and features high reliability, high security, simple network deployment, automatic AC discovery and configuration, and real-time management and maintenance.	The AP7110DN-AGN provides high-performance wireless services for large and medium enterprises in high-density scenarios. The AP7110DN-AGN can be flexibly deployed and work in both fit AP and bridge mode.
AP7110SN-GN	Single band: 2.4 GHz	IEEE 802.11b/g/n		

Typical networking modes are as follows:

Figure 1-1 Fit AP networking (AP mode)

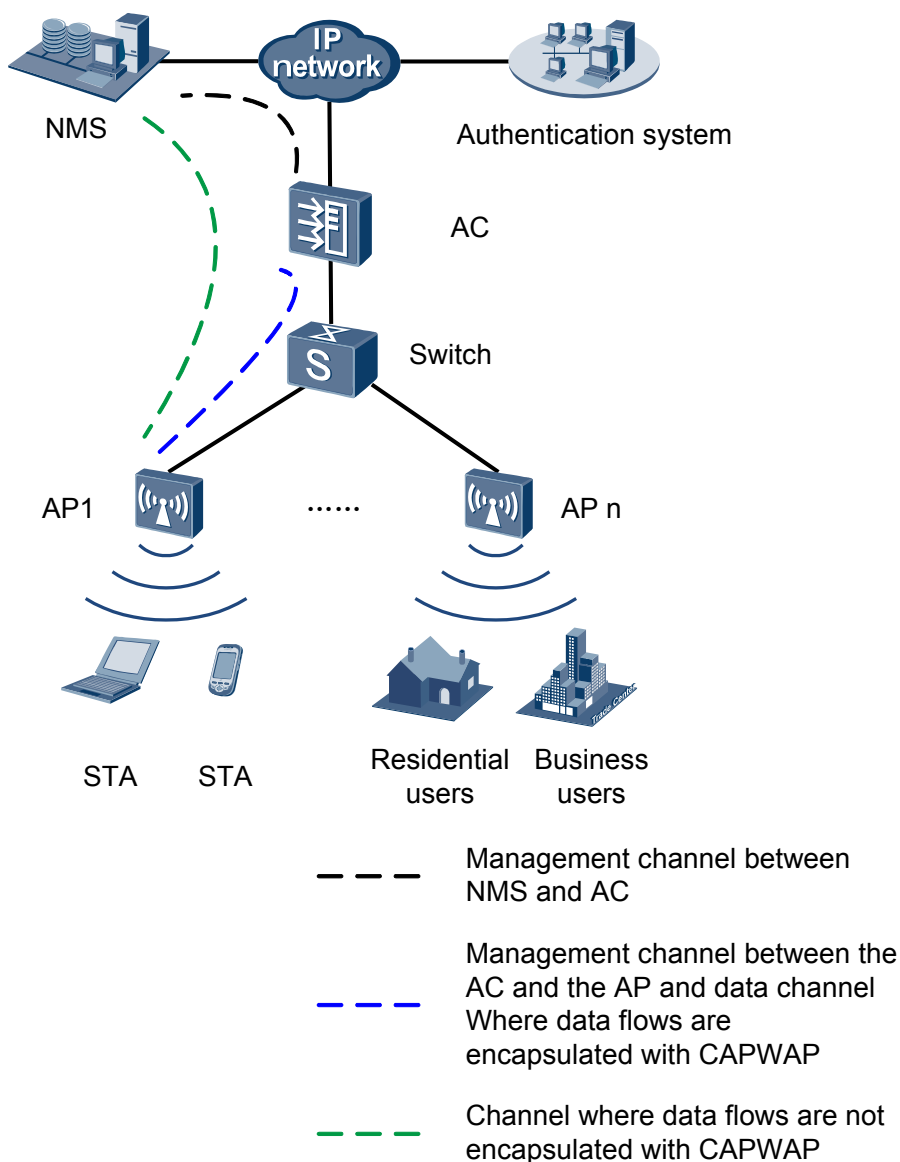

In this networking, the AP functions as a fit AP and provides only data forwarding functions. The AC is responsible for user access, AP go-online, AP management, authentication, routing, security, and QoS.

Figure 1-2 Fit AP networking (WDS mode: point-to-point)

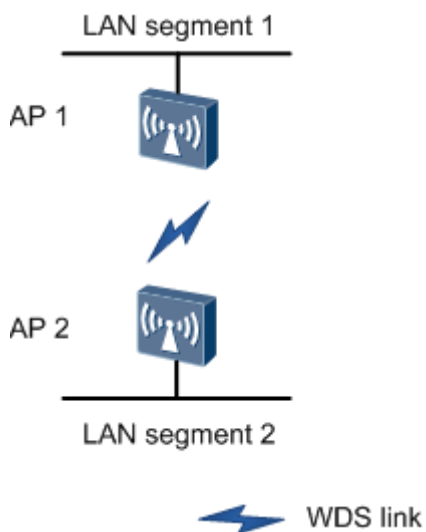
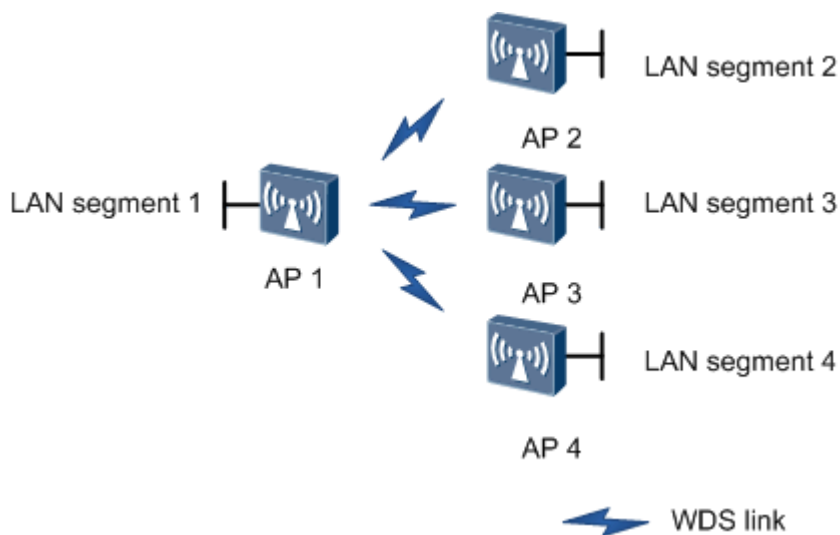
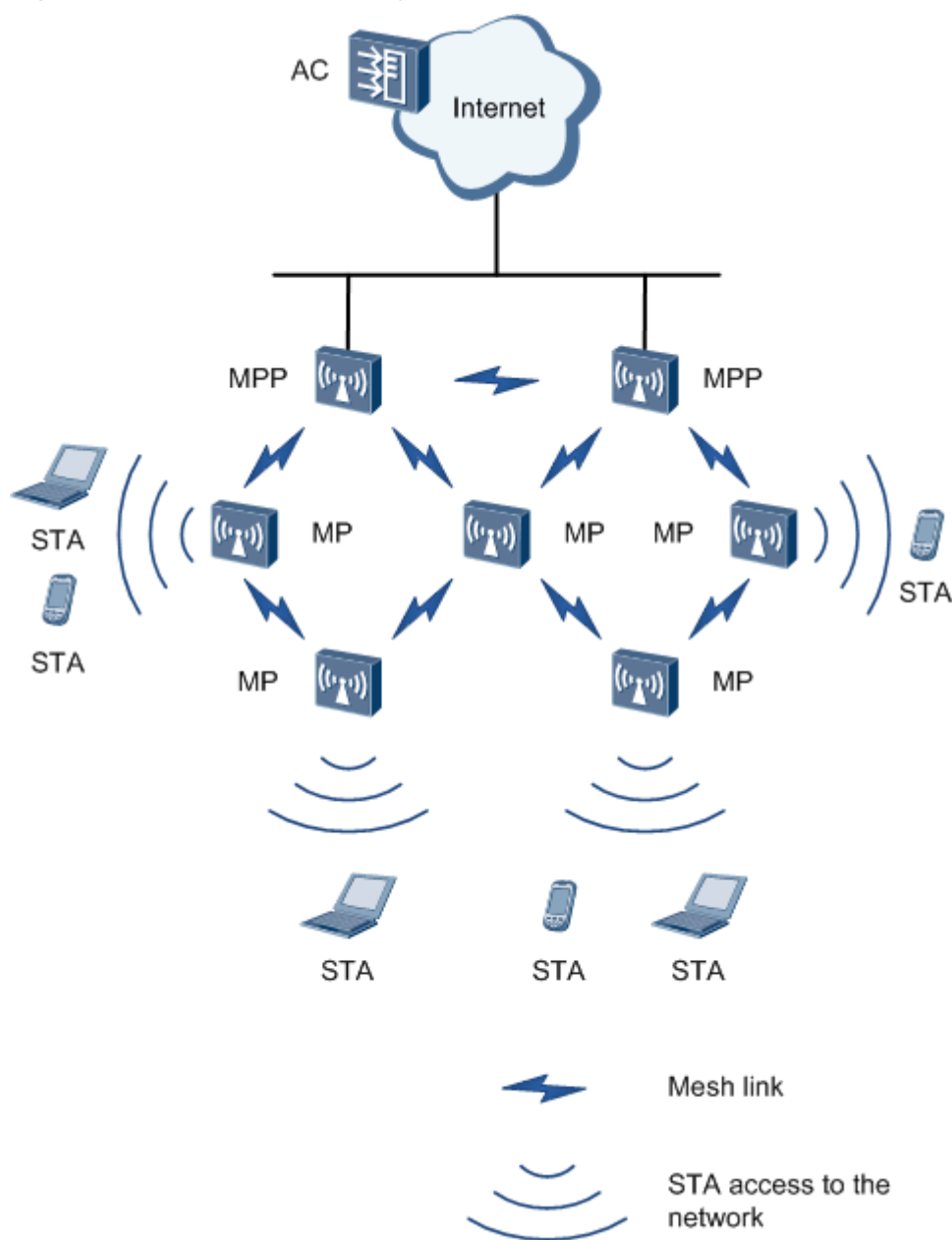

Figure 1-3 Fit AP networking (WDS mode: point-to-multipoint)



In this networking, the AP connects two or more independently wired or wireless LANs through wireless links to construct a network on which users can exchange data. In Wireless Distribution System (WDS) mode, the AP supports point-to-point (P2P) and point-to-multipoint (P2MP) networking modes. With 5 GHz and 2.4 GHz frequency bands, the AP can implement wireless bridging and access functions.

Figure 1-4 Fit AP mesh networking



On the preceding network, mesh routers function as mesh points (MPs) and are fully-meshed to establish an auto-configured and self-healing wireless mesh network (WMN). Mesh routers with the gateway function can work as the mesh portal points (MPPs) through which the WMN can provide access to the Internet. Terminals connect to mesh routers to access the WMN. The WMN uses dedicated mesh routing protocols to guarantee high transmission quality and is more applicable to scenarios that require high bandwidth and highly stable Internet connections.

1.2 Product Characteristics

The AP7110DN-AGN, and AP7110SN-GN have the following advantages on a WLAN.

Product Characteristics	Description
High-speed and reliable wireless access	<ul style="list-style-type: none"> ● AP7110DN-AGN: complies with IEEE 802.11a/b/g/n. ● AP7110SN-GN: complies with IEEE 802.11b/g/n. ● Supports 3 x 3 MIMO and provides a maximum rate of 450 Mbit/s. ● Supports Wi-Fi Multimedia (WMM) and priority mapping on the air interface and wired interface. ● Supports wired link integrity check. ● Supports load balancing. ● Supports roaming without service interruption in Fit AP mode. ● Supports AC dual-link backup and VRRP hot backup in Fit AP mode. ● Supports 11n beamforming. ● Uses the latest 802.11n chip to provide higher performance and wider coverage. ● Uses a metal shell and heat dissipation design to ensure high reliability.
Comprehensive user access control capability	<ul style="list-style-type: none"> ● Supports access control lists (ACLs) and implements user access control based on the user group policy. ● Provides fine-grained bandwidth management for each user. ● Supports user isolation policies. ● Supports unified authentication on the AC in Fit AP mode. ● Identifies the device type according to the organizationally unique identifier (OUI) in the MAC address, user agent (UA) information in an HTTP packet, and DHCP options in Fit AP mode. ● The RADIUS server delivers packet forwarding, security, and QoS policies according to the device type carried in the RADIUS authentication and accounting packets in Fit AP mode.
High network security	<p>Supports the following authentication and encryption modes:</p> <ul style="list-style-type: none"> ● Open system authentication ● WEP authentication/encryption ● WPA/WPA2-PSK authentication and encryption ● WPA/WPA2-802.1x authentication and encryption ● WAPI authentication and encryption ● Supports wireless intrusion detection system (WIDS), including rogue AP and STA detection, attack detection, STA/AP blacklist and whitelist.

Product Characteristics	Description
Flexible networking and environment adaptability	<ul style="list-style-type: none"> ● Provides flexible networking capabilities and applies to various application scenarios. Mesh and WDS scenarios are supported only in Fit AP mode. ● Has strong environment adaptability. The AP can automatically select the transmission rates, channels, and transmit power to adapt to various radio environments and avoid interference in real time. ● Adjusts bandwidth allocation based on the user quantity and environment to improve user experience. ● AP7110DN-AGN: supports the MIMO antenna system and connects to external dual-band antennas (2.4 GHz and 5 GHz). The antennas can be flexibly adjusted. ● Identifies interference sources such as bluetooth devices, microwave ovens, cordless phones, ZigBees, game controllers, 2.4 GHz/5 GHz wireless video and audio devices, and baby monitors in Fit AP mode and works with eSight to locate interference sources and display spectrums.
Easy device management and maintenance	<ul style="list-style-type: none"> ● Automatically goes online and loads the configuration, and supports plug-and-play (PnP) in Fit AP mode. ● Supports batch upgrade. ● Allows real-time monitoring on the network management system (NMS) to facilitate remote configuration and fast fault location. ● Supports the Link Layer Discovery Protocol (LLDP) to implement automatic link discovery and obtain the network topology.

2 Hardware Structure

About This Chapter

[2.1 AP7110DN-AGN](#)

[2.2 AP7110SN-GN](#)

2.1 AP7110DN-AGN

Appearance

Figure 2-1 shows the appearance of the AP7110DN-AGN.

 **NOTE**

The actual device appearance may be different from the following device appearance, but these differences will not affect device functions.

Figure 2-1 AP7110DN-AGN appearance



WARNING



There is a scald warning label attached on the device, warning you not to touch the device after the device has been operating for a long time.

Interfaces

The following figure shows interfaces on the AP7110DN-AGN.

Figure 2-2 Interfaces on the AP7110DN-AGN



As shown in **Figure 2-2**, the AP7110DN-AGN has the following interfaces.

1. Ground point: connects to a ground cable.
2. Console interface.
3. ETH/PoE interface: a 10/100/1000M interface, which connects to the wired Ethernet and supports the PoE power supply.
4. Default button: restores factory settings if you hold down the button more than 3s.
5. Power input interface: 12 V DC.
6. Lock interface: protects the AP against theft.

NOTE

Different power adapters are delivered with the AP products according to standards in the countries or regions where the AP products are delivered. These countries and regions are identified by the barcode on an AP's nameplate, including:

- EU (Europe)
- UK (United Kingdom)
- CN (China)
- AU (Australia)
- US (United States)
- USA (the AP is sold only in the U.S)

LED Indicators

Information Type	SYS LED	Link LED	WiFi LED	Description
Startup status	Steady green	-	-	The system is being initialized.
	Blinking green	-	-	Memory check, software system, and system initialization are all normal.

Information Type	SYS LED	Link LED	WiFi LED	Description
	Steady red	-	-	Memory check fails or the system software fails to be loaded.
Running and connection status	Blinking green once every 2s (0.5 Hz)	Off	Off	The system is running properly, but no Ethernet connection is available. Radios are disabled.
			Blinking green	The system is running properly, but no Ethernet connection is available. The AP has STAs connected to the 2.4 GHz band and is transmitting data. The indicator blinks more quickly when more data is being transmitted.
			Blinking yellow	The system is running properly, but no Ethernet connection is available. The AP has STAs connected to the 5 GHz band and is transmitting data. The indicator blinks more quickly when more data is being transmitted.
			Blinking green and yellow alternately	The system is running properly, but no Ethernet connection is available. The AP has STAs connected to the 2.4 GHz and 5 GHz bands.
	Blinking green once every 2s (0.5 Hz)	Steady or blinking green	Off	The system is running properly and the Ethernet connection is normal. Radios are disabled. The indicator blinks more quickly when more data is being transmitted.
			Blinking green	The system is running properly and the Ethernet connection is normal. The AP has STAs connected to the 2.4 GHz band and is transmitting data. The indicator blinks more quickly when more data is being transmitted.
			Blinking yellow	The system is running properly and the Ethernet connection is normal. The AP has STAs connected to the 5 GHz band and is transmitting data. The indicator blinks more quickly when more data is being transmitted.

Information Type	SYS LED	Link LED	WiFi LED	Description
			Blinking green and yellow alternately	The system is running properly and the Ethernet connection is normal. The AP has STAs connected to the 2.4 GHz and 5 GHz bands. The indicator blinks more quickly when more data is being transmitted.

2.2 AP7110SN-GN

Appearance

Figure 2-3 shows the appearance of the AP7110SN-GN.

 **NOTE**

The actual device appearance may be different from the following device appearance, but these differences will not affect device functions.

Figure 2-3 AP7110SN-GN appearance



There is a scald warning label attached on the device, warning you not to touch the device after the device has been operating for a long time.

Interfaces

The following figure shows interfaces on the AP7110SN-GN.

Figure 2-4 Interfaces on the AP7110SN-GN



As shown in **Figure 2-4**, the AP7110SN-GN has the following interfaces.

1. Ground point: connects to a ground cable.
2. Console interface.
3. ETH/PoE interface: a 10/100/1000M interface, which connects to the wired Ethernet and supports the PoE power supply.
4. Default button: restores factory settings if you hold down the button more than 3s.
5. Power input interface: 12 V DC.
6. Lock interface: protects the AP against theft.

NOTE

Different power adapters are delivered with the AP products according to standards in the countries or regions where the AP products are delivered. These countries and regions are identified by the barcode on an AP's nameplate, including:

- EU (Europe)
- UK (United Kingdom)
- CN (China)
- AU (Australia)
- US (United States)

LED Indicators

Information Type	SYS LED	Link LED	WiFi LED	Description
Startup status	Steady green	-	-	The system is being initialized.
	Blinking green	-	-	Memory check, software system, and system initialization are all normal.

Information Type	SYS LED	Link LED	WiFi LED	Description
	Steady red	-	-	Memory check fails or the system software fails to be loaded.
Running and connection status	Blinking green once every 2s (0.5 Hz)	Off	Off	The system is running properly, but no Ethernet connection is available. Radios are disabled.
	Blinking green once every 2s (0.5 Hz)	Off	Blinking green	The system is running properly, but no Ethernet connection is available. The AP has STAs connected and is transmitting data. The indicator blinks more quickly when more data is being transmitted.
	Blinking green once every 2s (0.5 Hz)	Steady or blinking green	Off	The system is running properly and the Ethernet connection is normal. Radios are disabled, and no STA is connected to the AP. The indicator blinks more quickly when more data is being transmitted.
	Blinking green once every 2s (0.5 Hz)	Steady or blinking green	Blinking green	The system is running properly and the Ethernet connection is normal. The AP has STAs connected and is transmitting data. The indicator blinks more quickly when more data is being transmitted.

3 Product Features

About This Chapter

- 3.1 WLAN Features
- 3.2 Network Features
- 3.3 QoS Features
- 3.4 Security Features
- 3.5 Maintenance Features
- 3.6 BYOD
- 3.7 Locating Service
- 3.8 Spectrum Analysis

3.1 WLAN Features

WLAN features supported by the AP are as follows:

- AP7110DN-AGN: complies with IEEE 802.11a/b/g/n.
- AP7110SN-GN: complies with IEEE 802.11b/g/n.
- AP7110DN-AGN and AP7110SN-GN: provides a maximum rate of 450 Mbit/s.
- Maximum ratio combining (MRC)
- Maximum-likelihood detection (MLD)
- Data unit aggregation, including A-MPDU (Tx/Rx) and A-MSDU (Rx only)
- AP7110DN-AGN: supports 802.11 dynamic frequency selection (DFS).
- Short GI in 20 MHz and 40 MHz modes
- Priority mapping and packet scheduling based on a Wi-Fi Multimedia (WMM) profile to implement priority-based data processing and forwarding
- Automatic and manual rate adjustment (the rate is adjusted automatically by default)
- WLAN channel management and channel rate adjustment

 **NOTE**

For details about WLAN channel management, see the *Country Code & Channel Compliance Table*.

- Automatic channel scanning and interference avoidance
- Service set identifier (SSID) hiding
- Signal sustain technology (SST)
- Unscheduled automatic power save delivery (U-APSD)
- Control and Provisioning of Wireless Access Points (CAPWAP) in Fit AP mode
- Automatic login in Fit AP mode
- Wireless distribution system (WDS) in Fit AP mode
- Mesh networking in Fit AP mode

3.2 Network Features

Network features supported by the AP are as follows:

- Compliance with IEEE 802.3u
- Auto-negotiation of the rate and duplex mode and automatic switchover between the Media Dependent Interface (MDI) and Media Dependent Interface Crossover (MDI-X)
- SSID-based VLAN assignment
- VLAN trunk on uplink Ethernet ports
- 4094 VLAN IDs (1-4094) and a maximum of 16 virtual APs (VAPs) for each radio
- AP control channel in tagged and untagged mode
- DHCP client, obtaining IP addresses through DHCP
- Centralized data forwarding and local data forwarding
- STA isolation in the same VLAN

- Access control lists (ACLs)
- Link Layer Discovery Protocol (LLDP)
- Uninterrupted service forwarding upon CAPWAP channel disconnection in Fit AP mode
- Unified authentication on the AC in Fit AP mode
- AC dual-link backup and VRRP hot backup in Fit AP mode

3.3 QoS Features

QoS features supported by the AP are as follows:

- Priority mapping and packet scheduling based on a Wi-Fi Multimedia (WMM) profile to implement priority-based data processing and forwarding
- WMM parameter management for each radio
- WMM power saving
- Priority mapping for upstream packets and flow-based mapping for downstream packets
- Queue mapping and scheduling
- User-based bandwidth limiting
- Adaptive bandwidth management (the system dynamically adjusts bandwidth based on the number of users and radio environment to improve user experience)

3.4 Security Features

Security features supported by the AP are as follows:

- Open system authentication
- WEP authentication/encryption
- WPA/WPA2-PSK authentication and encryption
- WPA/WPA2-802.1x authentication and encryption
- WAPI authentication and encryption
- Supports wireless intrusion detection system (WIDS), including rogue AP and STA detection, attack detection, STA/AP blacklist and whitelist.

3.5 Maintenance Features

Maintenance features supported by the AP are as follows:

- Unified management and maintenance on the AC in Fit AP mode
- Automatic login and configuration loading, and plug-and-play (PnP) in Fit AP mode
- WDS zero-configuration deployment in Fit AP mode
- Mesh network zero-configuration deployment in Fit AP mode
- Batch upgrade
- Local AP management through the serial interface or using Telnet
- Real-time configuration monitoring and fast fault location using the NMS
- System status alarm

3.6 BYOD

 **NOTE**

The AP supports bring your own device (BYOD) only in Fit AP mode.

BYOD features supported by the AP are as follows:

- Identifies the device type according to the organizationally unique identifier (OUI) in the MAC address.
- Identifies the device type according to the user agent (UA) information in an HTTP packet.
- Identifies the device type according to DHCP options.
- The RADIUS server delivers packet forwarding, security, and QoS policies according to the device type carried in the RADIUS authentication and accounting packets.

3.7 Locating Service

 **NOTE**

The AP supports the locating service only in Fit AP mode.

Locating service features supported by the AP are as follows:

- Locates tags manufactured by AeroScout or Ekahau.
- Locates Wi-Fi terminals.

3.8 Spectrum Analysis

 **NOTE**

The AP supports spectrum analysis only in Fit AP mode.

Spectrum analysis features supported by the AP are as follows:

- Identifies interference sources such as bluetooth devices, microwave ovens, cordless phones, ZigBee, game controllers, 2.4 GHz/5 GHz wireless video and audio devices, and baby monitors.
- Works with eSight to locate and perform spectrum analysis on interference sources.

4 Technical Specifications

About This Chapter

- [4.1 Basic Specifications](#)
- [4.2 Radio Specifications](#)
- [4.3 Standards Compliance](#)

4.1 Basic Specifications

Table 4-1 Basic specifications

Item		Description
Technical specifications	Dimensions (H x W x D)	200 mm x 200 mm x 45 mm
	Weight	1.0 kg
	System memory	<ul style="list-style-type: none">● 256 MB DDR3● 32 MB flash memory
Power specifications	Power input	<ul style="list-style-type: none">● DC 12 V \pm 10%● PoE power: -48 V DC● AP7110SN-GN: PoE function in compliance with IEEE 802.3af and 802.3at● AP7110DN-AGN: PoE function in compliance with IEEE 802.3at
	Maximum power consumption	<ul style="list-style-type: none">● AP7110DN-AGN: 15.7 W● AP7110SN-GN: 8.7 W NOTE The maximum power consumption depends on local laws.
Environment specifications	Operating temperature	-10°C to +55°C
	Storage temperature	-40°C to +70°C
	Operating humidity	5% to 95% (non-condensing)
	Waterproof grade	IP41
	Altitude	-60 m to 4000 m

4.2 Radio Specifications

Table 4-2 Radio specifications

Item	Description
Antenna type	Removable RP-SMA antenna

Item	Description			
Antenna gain	<ul style="list-style-type: none"> ● AP7110DN-AGN <ul style="list-style-type: none"> - 2.4 GHz: 2.5 dBi - 5 GHz: 4 dBi ● AP7110SN-GN: 2.5 dBi 			
Maximum number of concurrent users	≤256			
Maximum transmit power for each radio	20 dBm NOTE The actual transmit power depends on local laws and regulations. You can adjust the transmit power from the maximum transmit power by 20 dB, with a step of 1 dB. The adjustment range varies according to AP models.			
Maximum number of non-overlapping channels for AP7110DN-AGN	2.4 GHz	5 GHz	NOTE The number of non-overlapping channels varies in different countries. For details, see the <i>Country Code & Channel Compliance Table</i> CAUTION If the AP is delivered to the USA, pay attention to the following on channel and frequency band usage.	
	802.11b/g	802.11a		
	● 20 MHz: 3	● 20 MHz: 24		
	802.11n	802.11n		
	● 20 MHz: 3	● 20 MHz: 24		
	● 40 MHz: 1	● 40 MHz: 11		
Maximum number of non-overlapping channels for AP7110SN-GN	802.11b/g ● 20 MHz: 3 802.11n ● 20 MHz: 3 ● 40 MHz: 1			
Channel rate supported by the AP7110DN-AGN and AP7110SN-GN	802.11b: 1, 2, 5.5, and 11 Mbit/s			
	802.11g: 6, 9, 12, 18, 24, 36, 48, and 54 Mbit/s			
	802.11n data rate: ● AP7110DN-AGN: 2.4 GHz and 5 GHz ● AP7110SN-GN: 2.4 GHz			
	GI ^a = 800 ns		GI = 400 ns	
	20 MHz (Mbit/s)	40 MHz (Mbit/s)	20 MHz (Mbit/s)	40 MHz (Mbit/s)
	6.5 @ MCS ^b 0	13.5 @ MCS0	7.2 @ MCS0	15 @ MCS0

Item	Description			
	13 @ MCS1	27 @ MCS1	14.4 @ MCS1	30 @ MCS1
	19.5 @ MCS2	40.5 @ MCS2	21.7 @ MCS2	45 @ MCS2
	26 @ MCS3	54 @ MCS3	28.9 @ MCS3	60 @ MCS3
	39 @ MCS4	81 @ MCS4	43.3 @ MCS4	90 @ MCS4
	52 @ MCS5	108 @ MCS5	57.8 @ MCS5	120 @ MCS5
	58.5 @ MCS6	121.5 @ MCS6	65 @ MCS6	135 @ MCS6
	65 @ MCS7	135 @ MCS7	72.2 @ MCS7	150 @ MCS7
	13 @ MCS8	27 @ MCS8	14.4 @ MCS8	30 @ MCS8
	26 @ MCS9	54 @ MCS9	28.9 @ MCS9	60 @ MCS9
	39 @ MCS10	81 @ MCS10	43.3 @ MCS10	90 @ MCS10
	52 @ MCS11	108 @ MCS11	57.8 @ MCS11	120 @ MCS11
	78 @ MCS12	162 @ MCS12	86.7 @ MCS12	180 @ MCS12
	104 @ MCS13	216 @ MCS13	115.6 @ MCS13	240 @ MCS13
	117 @ MCS14	243 @ MCS14	130 @ MCS14	270 @ MCS14
	130 @ MCS15	270 @ MCS15	144.4 @ MCS15	300 @ MCS15
	19.5 @ MCS16	40.5 @ MCS16	21.7 @ MCS16	45 @ MCS16
	39 @ MCS17	81 @ MCS17	43.3 @ MCS17	90 @ MCS17
	58.5 @ MCS18	121.5 @ MCS18	65 @ MCS18	135 @ MCS18
	78 @ MCS19	162 @ MCS19	86.7 @ MCS19	180 @ MCS19
	117 @ MCS20	243 @ MCS20	130 @ MCS20	270 @ MCS20
	156 @ MCS21	324 @ MCS21	173.3 @ MCS21	360 @ MCS21
	175.5 @ MCS22	364.5 @ MCS22	195 @ MCS22	405 @ MCS22
	195 @ MCS23	405 @ MCS23	216.7 @ MCS23	450 @ MCS23
<p>NOTE</p> <p>a. The guard interval (GI) is the period in nanoseconds the radio listens between packets. The GI introduces immunity to propagation delays.</p> <p>b. The modulation coding scheme (MCS) index determines the spatial stream quantity, modulation, coding rate, and data rate.</p>				

Item	Description			
Receiver sensitivity of the AP7110SN-GN	802.11b (CCK): <ul style="list-style-type: none"> ● -97 dBm @ 1 Mbit/s ● -92 dBm @ 2 Mbit/s ● -93 dBm @ 5.5 Mbit/s ● -89 dBm @ 11 Mbit/s 	802.11g (non-HT20): <ul style="list-style-type: none"> ● -91 dBm @ 6 Mbit/s ● -90 dBm @ 9 Mbit/s ● -90 dBm @ 12 Mbit/s ● -88 dBm @ 18 Mbit/s ● -84 dBm @ 24 Mbit/s ● -81 dBm @ 36 Mbit/s ● -77 dBm @ 48 Mbit/s ● -74 dBm @ 54 Mbit/s 	802.11n (HT20): <ul style="list-style-type: none"> ● -90 dBm @ MCS0 ● -90 dBm @ MCS1 ● -88 dBm @ MCS2 ● -82 dBm @ MCS3 ● -79 dBm @ MCS4 ● -75 dBm @ MCS5 ● -73 dBm @ MCS6 ● -72 dBm @ MCS7 ● -87 dBm @ MCS8 ● -86 dBm @ MCS9 ● -86 dBm @ MCS10 ● -83 dBm @ MCS11 ● -79 dBm @ MCS12 ● -75 dBm @ MCS13 ● -74 dBm @ MCS14 ● -73 dBm @ MCS15 ● -87 dBm @ MCS16 ● -86 dBm @ MCS17 ● -86 dBm @ MCS18 ● -83 dBm @ MCS19 ● -79 dBm @ MCS20 	802.11n (HT40): <ul style="list-style-type: none"> ● -86 dBm @ MCS0 ● -86 dBm @ MCS1 ● -84 dBm @ MCS2 ● -80 dBm @ MCS3 ● -77 dBm @ MCS4 ● -72 dBm @ MCS5 ● -70 dBm @ MCS6 ● -68 dBm @ MCS7 ● -86 dBm @ MCS8 ● -86 dBm @ MCS9 ● -84 dBm @ MCS10 ● -80 dBm @ MCS11 ● -77 dBm @ MCS12 ● -72 dBm @ MCS13 ● -71 dBm @ MCS14 ● -70 dBm @ MCS15 ● -86 dBm @ MCS16 ● -86 dBm @ MCS17 ● -84 dBm @ MCS18 ● -80 dBm @ MCS19 ● -77 dBm @ MCS20

Item	Description			
			<ul style="list-style-type: none">● -75 dBm @ MCS21● -74 dBm @ MCS22● -73 dBm @ MCS23	<ul style="list-style-type: none">● -72 dBm @ MCS21● -71 dBm @ MCS22● -70 dBm @ MCS23

Item	Description			
Receiver sensitivity of the AP7110DN-AGN	2.4 GHz 802.11b (CCK) <ul style="list-style-type: none"> ● -97 dBm @ 1 Mbit/s ● -92 dBm @ 2 Mbit/s ● -93 dBm @ 5.5 Mbit/s ● -89 dBm @ 11 Mbit/s 	2.4 GHz 802.11g (non-HT20) <ul style="list-style-type: none"> ● -91 dBm @ 6 Mbit/s ● -90 dBm @ 9 Mbit/s ● -90 dBm @ 12 Mbit/s ● -88 dBm @ 18 Mbit/s ● -84 dBm @ 24 Mbit/s ● -81 dBm @ 36 Mbit/s ● -77 dBm @ 48 Mbit/s ● -74 dBm @ 54 Mbit/s 	2.4 GHz 802.11n (HT20) <ul style="list-style-type: none"> ● -90 dBm @ MCS0 ● -90 dBm @ MCS1 ● -88 dBm @ MCS2 ● -82 dBm @ MCS3 ● -79 dBm @ MCS4 ● -75 dBm @ MCS5 ● -73 dBm @ MCS6 ● -72 dBm @ MCS7 ● -87 dBm @ MCS8 ● -86 dBm @ MCS9 ● -86 dBm @ MCS10 ● -83 dBm @ MCS11 ● -79 dBm @ MCS12 ● -75 dBm @ MCS13 ● -74 dBm @ MCS14 ● -73 dBm @ MCS15 ● -87 dBm @ MCS16 ● -86 dBm @ MCS17 ● -86 dBm @ MCS18 ● -83 dBm @ MCS19 ● -79 dBm @ MCS20 	2.4 GHz 802.11n (HT40) <ul style="list-style-type: none"> ● -86 dBm @ MCS0 ● -86 dBm @ MCS1 ● -84 dBm @ MCS2 ● -80 dBm @ MCS3 ● -77 dBm @ MCS4 ● -72 dBm @ MCS5 ● -70 dBm @ MCS6 ● -68 dBm @ MCS7 ● -86 dBm @ MCS8 ● -86 dBm @ MCS9 ● -84 dBm @ MCS10 ● -80 dBm @ MCS11 ● -77 dBm @ MCS12 ● -72 dBm @ MCS13 ● -71 dBm @ MCS14 ● -70 dBm @ MCS15 ● -86 dBm @ MCS16 ● -86 dBm @ MCS17 ● -84 dBm @ MCS18 ● -80 dBm @ MCS19 ● -77 dBm @ MCS20

Item	Description			
			<ul style="list-style-type: none">● -75 dBm @ MCS21● -74 dBm @ MCS22● -73 dBm @ MCS23	<ul style="list-style-type: none">● -72 dBm @ MCS21● -71 dBm @ MCS22● -70 dBm @ MCS23

Item	Description			
	5 GHz 802.11a (non-HT20) ● -91 dBm @ 6 Mbit/s ● -90 dBm @ 9 Mbit/s ● -89 dBm @ 12 Mbit/s ● -86 dBm @ 18 Mbit/s ● -83 dBm @ 24 Mbit/s ● -80 dBm @ 36 Mbit/s ● -75 dBm @ 48 Mbit/s ● -74 dBm @ 54 Mbit/s	5 GHz 802.11n (HT20) ● -90 dBm @ MCS0 ● -88 dBm @ MCS1 ● -86 dBm @ MCS2 ● -81 dBm @ MCS3 ● -78 dBm @ MCS4 ● -74 dBm @ MCS5 ● -72 dBm @ MCS6 ● -71 dBm @ MCS7 ● -89 dBm @ MCS8 ● -86 dBm @ MCS9 ● -84 dBm @ MCS10 ● -80 dBm @ MCS11 ● -77 dBm @ MCS12 ● -72 dBm @ MCS13 ● -70 dBm @ MCS14 ● -69 dBm @ MCS15 ● -89 dBm @ MCS16 ● -86 dBm @ MCS17 ● -84 dBm @ MCS18 ● -80 dBm @ MCS19 ● -77 dBm @ MCS20	5 GHz 802.11n (HT40) ● -87 dBm @ MCS0 ● -85 dBm @ MCS1 ● -83 dBm @ MCS2 ● -79 dBm @ MCS3 ● -75 dBm @ MCS4 ● -71 dBm @ MCS5 ● -68 dBm @ MCS6 ● -67 dBm @ MCS7 ● -86 dBm @ MCS8 ● -83 dBm @ MCS9 ● -81 dBm @ MCS10 ● -76 dBm @ MCS11 ● -73 dBm @ MCS12 ● -69 dBm @ MCS13 ● -68 dBm @ MCS14 ● -66 dBm @ MCS15 ● -86 dBm @ MCS16 ● -83 dBm @ MCS17 ● -81 dBm @ MCS18 ● -76 dBm @ MCS19 ● -73 dBm @ MCS20	

Item	Description			
		<ul style="list-style-type: none"> ● -72 dBm @ MCS21 ● -70 dBm @ MCS22 ● -69 dBm @ MCS23 	<ul style="list-style-type: none"> ● -69 dBm @ MCS21 ● -68 dBm @ MCS22 ● -66 dBm @ MCS23 	

4.3 Standards Compliance

Safety standards

- UL 60950-1
- CAN/CSA 22.2 No.60950-1
- IEC 60950-1
- EN 60950-1
- GB 4943

Radio standards

AP7110DN-AGN:

- ESTI EN 300 328
- ESTI EN 301 893
- FCC Part 15C: 15.247
- FCC Part 15C: 15.407
- RSS-210

AP7110SN-GN:

- ESTI EN 300 328
- FCC Part 15C: 15.247
- RSS-210

EMC standards

- EN 301.489-1
- EN 301.489-17
- FCC Part 15
- ICES-003
- YD/T 1312.2-2004
- ITU k.21
- GB 9254
- GB 17625.1

IEEE standards

AP7110DN-AGN:

- IEEE 802.11a/b/g
- IEEE 802.11n
- IEEE 802.11h
- IEEE 802.11d
- IEEE 802.11e

AP7110SN-GN:

- IEEE 802.11b/g
- IEEE 802.11n
- IEEE 802.11h
- IEEE 802.11d
- IEEE 802.11e

Security standards

- 802.11i, Wi-Fi Protected Access 2 (WPA2), and WPA
- 802.1X
- Advanced Encryption Standards (AES) and Temporal Key Integrity Protocol (TKIP)
- EAP Type (s)

Environment standards

- ETSI 300 019-2-2
- ETSI 300 019-2-3

EMF

- CENELEC EN 62311
- CENELEC EN 50385
- OET65
- RSS-102

RoSH

- Directive 2002/95/EC

Reach

- Directive 1907/2006/EC

WEEE

- Directive 2002/96/EC